



DISPENSERS



POMPE



CONTALITRI



PISTOLE



FILTRAZIONE

MONITORAGGIO
DEL LIQUIDO

CARRY

CARATTERISTICHE

- FACILE DA MONTARE
- SICURA DA SPOSTARE
- APPLICAZIONE A LUNGA DURATA

La pompa PIUSI CARRY 3000 è una pompa DC di travaso diesel progettata per soddisfare le esigenze di chi è alla ricerca di una pompa portatile di alta qualità e lunga durata. CARRY 3000 è dotata di una robusta maniglia per facilitare il trasporto ed è completa di tubo di erogazione, cavi elettrici e pistola di erogazione.

PRESTAZIONI

FINO A

70 L/MIN

PORTATA

VOLTAGGIO

12/24 V

POTENZA

30 MIN

CICLO DI FUNZIONAMENTO



CARRY PANTHER

CARRY



CARRY 3000 INLINE

PACKAGING

CODICE	PESO		PACKAGING			N° SCATOLE/EUROPALLET	
	KG	LB	MM	POLLICI	PZ/SCATOLA	✕	
FO022300C	4,2	9,3	260X235X164	-	1	84	120
FO022400C	4,2	9,3	260X235X164	-	1	84	120
FO0223260	4,2	9,3	260X235X164	-	1	84	120
FO0224240	4,2	9,3	260X235X164	-	1	84	120
FO034004B	4,2	9,3	260X235X164	-	1	84	120
FO034104C	4,2	9,3	260X235X164	-	1	84	120



ARROTOLATORI
PER TUBO



ACCESSORI



MERCHANDISING

PIUSI[®]



ARIA



ANTIGELO



AdBlue[®]



BIODIESEL



DIESEL



ALIMENTI



BENZINA



GRASSO



KEROSENE



OLIO



ACQUA



LAVAVETRI

TABELLA

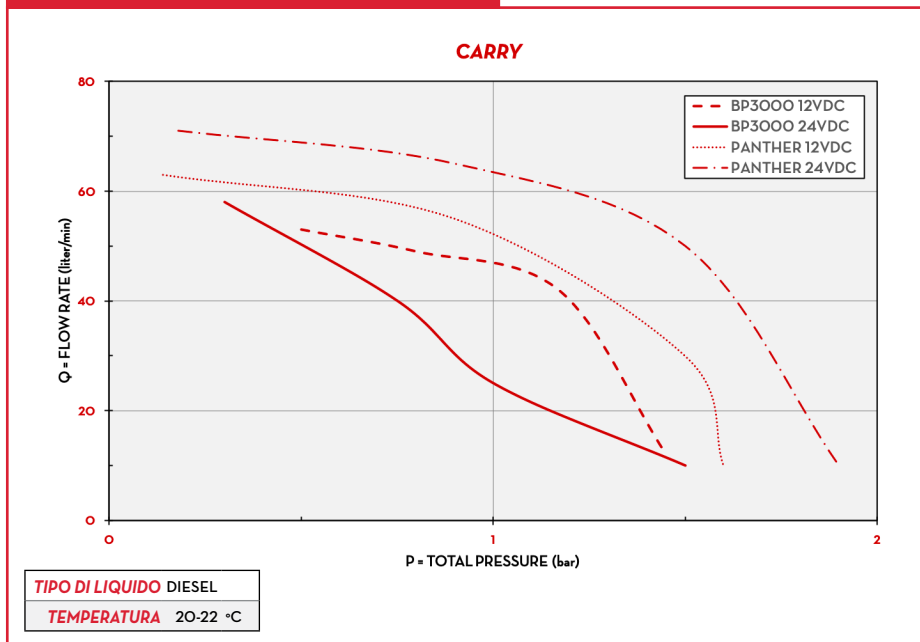

NELLA SCATOLA

- POMPA CARRY
- MANIGLIA
- TUBO DI EROGAZIONE
- CAVO ELETTRICO CON MORSETTI
- COLLEGAMENTI

DETTAGLI



DIMENSIONI

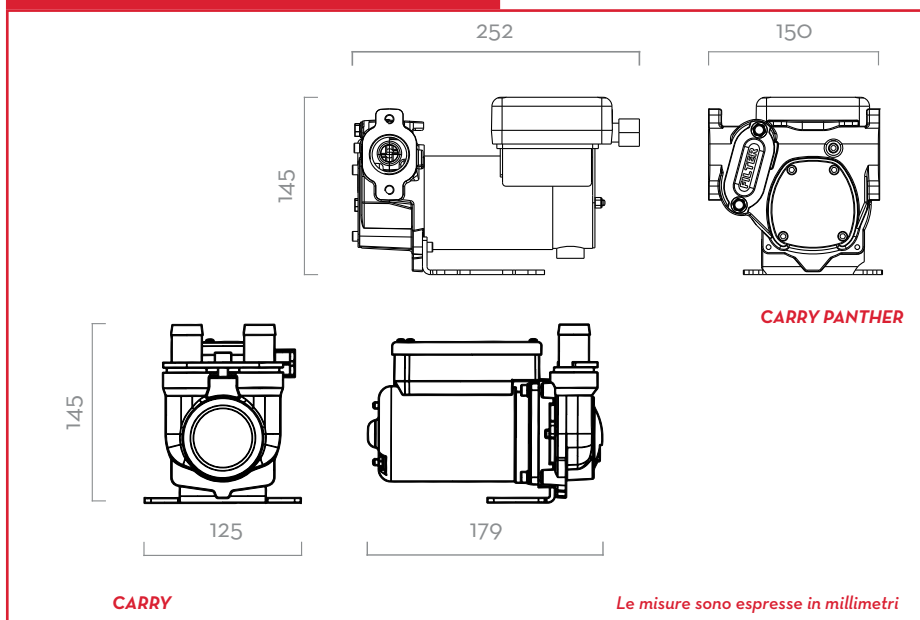

MATERIALI

- CORPO: GHISA
- ROTORE: ACCIAIO SINTERIZZATO
- PALETTE: RESINA ACETALICA
- GUARNIZIONE: NBR
- ALBERO: ACCIAIO

DATI TECNICI

CODICE	DESCRIZIONE	TIPO LIQUIDI	PORTATA		VOLTAGGIO			FUSIBILE	CICLO DI FUNZIONAMENTO	GIRI/MIN	MAX. PRESSIONE	SELETTORE ON/OFF	INGRESSO/USCITA
			L/MIN	GPM	DC V	POTENZA WATT	A MAX.						
FOO22300C	CARRY 3000 12 V	D	50	13	12	300	24	25	30	2900	1,5	SÌ	-
FOO22400C	CARRY 3000 24 V / 12 V	D	50/30	13/6	24/12	310/80	13/6,5	15	30	2900/1500	1,5	SÌ	-
FOO223260	CARRY 3000 INLINE 12 V	D	50	13	12	300	24	25	30	2900	1,5	SÌ	3/4"
FOO224240	CARRY 3000 INLINE 24 V	D	50/30	13/6	24/12	310/80	24	15	30	2900/1500	1,5	SÌ	3/4"
FOO34004B	CARRY PANTHER 12 V	D	56	15	12	420	13/6,5	-	30	2900	-	SÌ	1"
FOO34104C	CARRY PANTHER 12 V / 24 V	D	35/70	9/18	24/12	600/200	13/6,5	-	30	3500/1800	-	SÌ	1"

CARRY