



FUEL MANAGEMENT SYSTEMS



DISPENSERS



KITS



POMPE



CONTALITRI



PISTOLE

FILTROLL

CARATTERISTICHE

- FILTRAZIONE A DUE FASI
- TUBO SPIRALATO
- FACILE DA MANEGGIARE
- RUOTE DI GRANDE DIAMETRO

PIUSI FILTROLL è un innovativo gruppo portatile che assicura la doppia filtrazione completa di qualsiasi tipo di serbatoio, assorbendo acqua e impurità. La robusta struttura carrellata consente all'operatore di spostare facilmente questo gruppo in qualsiasi condizione. È dotato di tubo di aspirazione e valvola di fondo integrata.

PERFORMANCE

FINO A

56 L/MIN

PORTATA

AC/DC

VOLTAGGIO

POTENZA

30μ

ASSORBIMENTO ACQUA

FILTRAZIONE

5μ

IMPURITÀ

FILTRAZIONE



FILTROLL

PACKAGING

| CODICE | PESO | | PACKAGING | | |
|-----------|------|------|-------------|----------------|---------|
| | KG | LBS | MM | INCH | PCS/BOX |
| FO0506000 | 35 | 77,2 | 790X590X590 | 31,1X23,2X23,2 | 1 |
| FO050606A | 40 | 88,2 | 790X590X590 | 31,1X23,2X23,2 | 1 |



FILTRAZIONE



MONITORAGGIO FLUIDI



ARROTATORI



ACCESSORI



MERCHANDISE

PIUSI



ARIA



ANTIGELO



AdBlue®



BIODIESEL



DIESEL



ALIMENTI



BENZINA



GRASSO



KEROSENE



OLIO



ACQUA



LAVAVETRI

GRAFICO

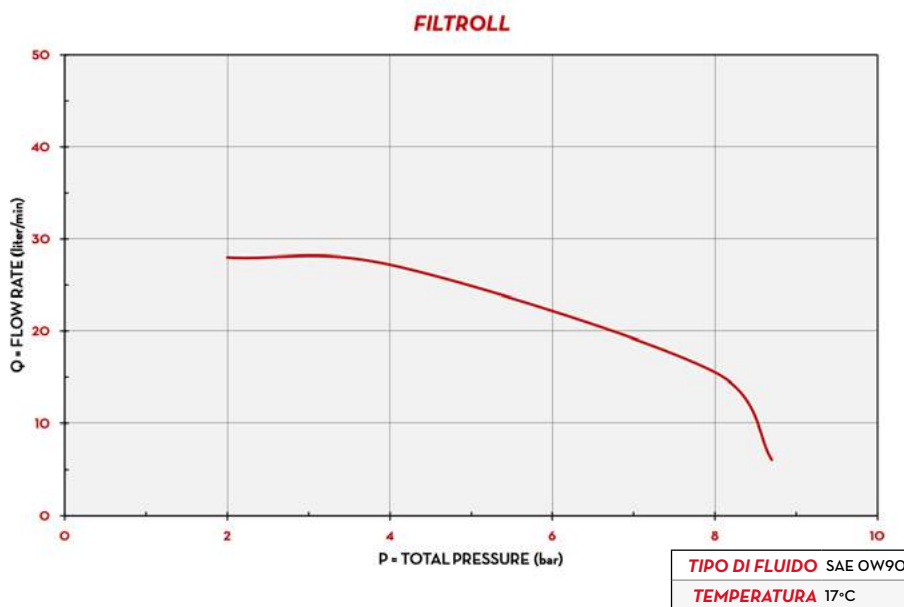

DENTRO LA SCATOLA

- GRUPPO FILTROLL
- TUBO DI ASPIRAZIONE
- TUBO DI MANDATA
- PISTOLA
- MANUALE ISTRUZIONI

DETTAGLI



FILTRAZIONE A DUE FASI



FILTRI ACQUA/IMPURITÀ

DIMENSIONI

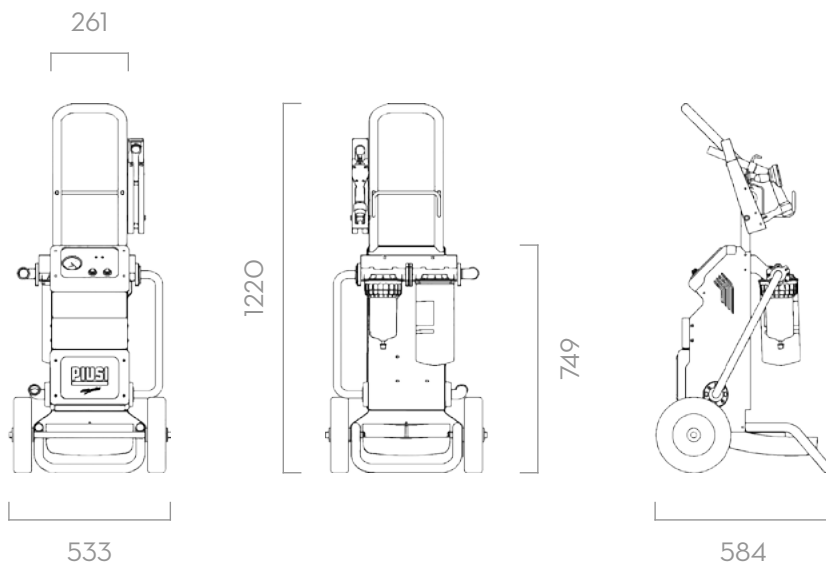

Dimensioni espresse in millimetri

MATERIALI

- CORPO: GHISA
- ROTORE: ACCIAIO SINTERIZZATO
- PALETTE: TECNOPOLIMERO
- ALBERO: ACCIAIO
- FILTRO: CARTA FILTRANTE ASSORBENTE

DATI TECNICI

| CODICE | DESCRIZIONE | TIPO DI FLUIDO | PORTATA | | VOLTAGGIO | | | PUMP | LUNGH. TUBO | |
|-----------|---------------------|----------------|---------|------|---------------------|-----------------|--------------|-----------|------------------|---------------------|
| | | | L/MIN | GPM | AC V/ HZ DC VOLT | POTENZA WATT | AMP. MAX. | TIPO | MANDATA M/FT. | ASPIRAZIONE M/FT |
| FO0506000 | FILTROLL DIESEL | D | 56 | 14,8 | 230/50-60 | 350/600 | 3/6 | PANTH. 56 | 4 / 13,1 | 3 / 9,8 |
| FO050606A | FILTROLL 12V DIESEL | D | 56 | 14,8 | 12 | 300 | 35 | PANTH. DC | 4 / 13,1 | 4 / 13,1 |

DISPONIBILE NELLE VERSIONI 230V/60HZ, 120V/60HZ

FILTROLL