



MCBOX B.SMART

CARATTERISTICHE

- IDEALE PER INSTALLAZIONI ESISTENTI
- ADATTO AD OGNI POMPA
- INPUT PER CONTALITRI PULSER
- B.SMART CLOUD SOFTWARE INCLUSO

MCBOX è un pannello elettronico che permette di controllare qualsiasi tipo di pompa AC/DC, contalitri pulser, pistola e connettori di livello carburante. Il prodotto ideale per aggiornare un'installazione già esistente o per un assemblaggio su misura. Con MCBOX B.SMART il sistema di gestione consumi carburante è incluso. Nessun software da installare sul proprio PC: B.SMART è completamente in Cloud e permette di monitorare tutte le transazioni in tempo reale da qualsiasi impianto in cui sia installato MCBOX B.SMART. La comunicazione tra MCBOX B.SMART, la APP mobile e il software in Cloud è semplice ed immediata.

PERFORMANCE

AC/DC

VOLTAGGIO

POTENZA

UP FINO A

500

MEMORIZZABILI

TRANSAZIONI

**VERSIONE
A 2 POMPE**

OUTPUT

BLUETOOTH

CONNESSIONE



MCBOX B.SMART



PACKAGING

CODICE	PESO		PACKAGING			N. BOX / EUROPALLET	
	KG	LBS	MM	INCH	PCS/BOX	✕	

AC VERSIONS

FO0599000	5,2	11,5	300X300X180	11.8X11.8X7.1	1	-	-
FO0599040	5,2	11,5	300X300X180	11.8X11.8X7.1	1	-	-
FO0599080	5,2	11,5	300X300X180	11.8X11.8X7.1	1	-	-
FO0599200	5,3	11,6	300X300X180	11.8X11.8X7.1	1	-	-
FO0599240	5,3	11,6	300X300X180	11.8X11.8X7.1	1	-	-
FO0599280	5,3	11,6	300X300X180	11.8X11.8X7.1	1	-	-

DC VERSIONS

FO0599010	5,4	11,8	300X300X180	11.8X11.8X7.1	1	-	-
FO0599050	5,4	11,8	300X300X180	11.8X11.8X7.1	1	-	-
FO0599090	5,4	11,8	300X300X180	11.8X11.8X7.1	1	-	-
FO0599060	5,4	11,8	300X300X180	11.8X11.8X7.1	1	-	-
FO0599070	5,4	11,8	300X300X180	11.8X11.8X7.1	1	-	-
FO0599110	5,4	11,8	300X300X180	11.8X11.8X7.1	1	-	-



FILTRAZIONE



MONITORAGGIO FLUIDI



ARROTOLATORI



ACCESSORI



MERCHANDISE



ARIA



ANTIGELO



AdBlue®



BIODIESEL



DIESEL



ALIMENTI



BENZINA



GRASSO



KEROSENE



OLIO



ACQUA



LAVAVETRI

SCHEMA DI CONNESSIONE



CONTROLLO POMPA



CONTALITRI AD IMPULSI



INDICATORE DI LIVELLO



INTERRUTTORE PISTOLA



DENTRO LA SCATOLA

- MCBOX B.SMART
- ADD-ON DRIVER ACCESS
- MANUALE ISTRUZIONI

DETTAGLI



SERRANDA

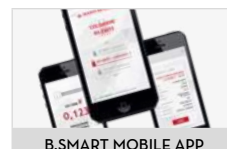

B.SMART MOBILE APP



B.SMART CLOUD SOFTWARE



FACILE ACCESSO ALLE CONNESSIONI

DIMENSIONI

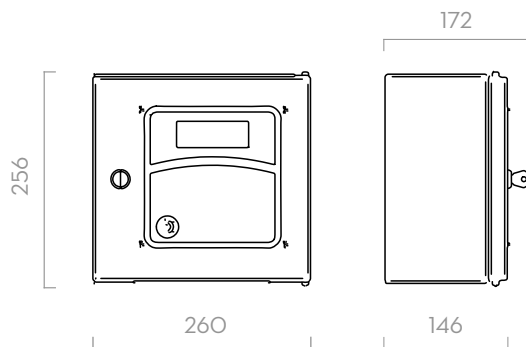

Dimensioni espresse in millimetri

DATI TECNICI

CODICE	DESCRIZIONE	TIPO DI FLUIDO	VOLTAGGIO			B.SMART CLOUD	
			AC V./HZ DC VOLT	POTENZA WATT	AMP. MAX.		
AC VERSIONS							
FO0599000	MCBOX 100-240V B.SMART 10 DRIVERS	ANY	100V-240V	50/60 HZ	5W	15 A	INCLUSA
FO0599040	MCBOX 100-240V B.SMART 20 DRIVERS	ANY	100V-240V	50/60 HZ	5W	15 A	INCLUSA
FO0599080	MCBOX 100-240V B.SMART 50 DRIVERS	ANY	100V-240V	50/60 HZ	5W	15 A	INCLUSA
FO0599200	MCBOX 100-240V B.SMART 10 DRIVERS 2 PUMPS	ANY	100V-240V	50/60 HZ	5W	15 A	INCLUSA
FO0599240	MCBOX 100-240V B.SMART 20 DRIVERS 2 PUMPS	ANY	100V-240V	50/60 HZ	5W	15 A	INCLUSA
FO0599280	MCBOX 100-240V B.SMART 50 DRIVERS 2 PUMPS	ANY	100V-240V	50/60 HZ	5W	15 A	INCLUSA
DC VERSIONS							
FO0599010	MCBOX 12V B.SMART 10 DRIVERS	ANY	12 V	-	5W	50 A	INCLUSA
FO0599050	MCBOX 12V B.SMART 20 DRIVERS	ANY	12 V	-	5W	50 A	INCLUSA
FO0599090	MCBOX 12V B.SMART 50 DRIVERS	ANY	12 V	-	5W	50 A	INCLUSA
FO0599060	MCBOX 24V B.SMART 10 DRIVERS	ANY	24 V	-	5W	25 A	INCLUSA
FO0599070	MCBOX 24V B.SMART 20 DRIVERS	ANY	24 V	-	5W	25 A	INCLUSA
FO0599110	MCBOX 24V B.SMART 50 DRIVERS	ANY	24 V	-	5W	25 A	INCLUSA

MCBOX B.SMART