



FUEL MANAGEMENT
SYSTEMS



DISPENSERS



KITS



POMPE



CONTALITRI



PISTOLE

DRUM

CARATTERISTICHE

- FACILE DA MONTARE
- ADATTO A TUTTI I FUSTI
- POMPE DIVERSE PER OGNI ESIGENZA
- VERSIONI DC E AC

PIUSI DRUM è un gruppo di travaso carburante compatto collegabile a fusti grazie all'attacco rapido da 2". Disponibile con diverse pompe, il gruppo è (sempre) dotato di un tubo di aspirazione telescopico e del portapistola posto sopra il fusto, vicino alla pompa, per operazioni facili, pulite e sicure. Contalitri meccanico K33 disponibile su richiesta.

PERFORMANCE

FINO A

80 L/MIN

PORTATA

AC/DC

VOLTAGGIO

POTENZA

± 1%

PRECISIONE



DRUM PANTHER 56 K33



DRUM BIPUMP 12V



PACKAGING

CODICE		PESO		PACKAGING		
WITHOUT METER	WITH METER	KG	LBS	MM	INCH	PCS/BOX
OO0271P00	OO0272P00	13,5	29,8	480X370X265	18,3X14,6X10,4	1
OO0273P00	OO0274P00	14,4	31,7	480X370X265	18,3X14,6X10,4	1
FO022201A	FO022205A	20,7	45,6	480X370X265	18,3X14,6X10,4	1
FO022202A	FO022206A	20,7	45,6	480X370X265	18,3X14,6X10,4	1
FO022203A	FO022207A	21,6	47,6	480X370X265	18,3X14,6X10,4	1
FO022204A	FO022208A	21,6	47,6	480X370X265	18,3X14,6X10,4	1
-	FO034111C	14,7	31,7	480X370X265	18,3X14,6X10,4	1



FILTRAZIONE



MONITORAGGIO FLUIDI



ARROTOLATORI



ACCESSORI



MERCHANDISE



ARIA



ANTIGELO



AdBlue®



BIODIESEL



DIESEL



ALIMENTI



BENZINA



GRASSO



KEROSENE



OLIO



ACQUA



LAVAVETRI

GRAFICO

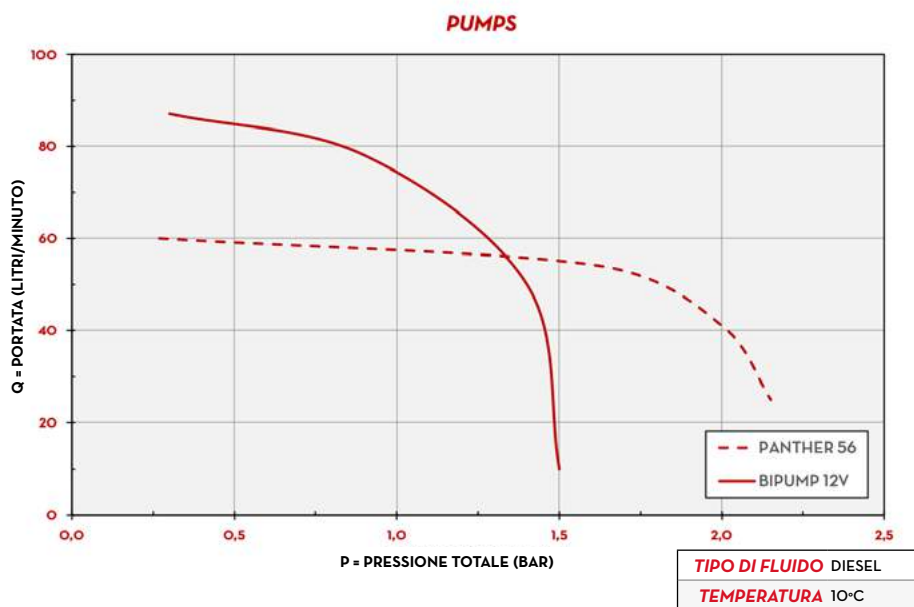

DIMENSIONI

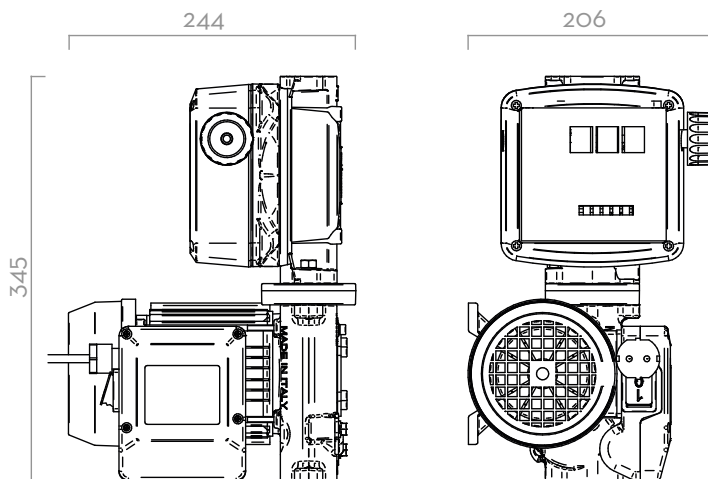

Dimensioni espresse in millimetri

DENTRO LA SCATOLA

- GRUPPO DRUM
- TUBO DI ASPIRAZIONE TELESCOPICO
- TUBO DI MANDATA
- PISTOLA
- CONNETTORE 2"
- CONTALITRI MECCANICO K33 (SU RICHIESTA)
- MANUALE ISTRUZIONI

DETTAGLI



COMPONENTI

- **POMPA:**
PANTHER AC PAG. 102
BIPUMP PAG. 116
PANTHER DC PAG. 114
- **CONTALITRI:**
K33 PAG. 146

DATI TECNICI

CODICE		DESCRIZIONE	TIPO DI FLUIDO	PORTATA		VOLTAGGIO			METER	NOZZLE	INGRESSO	HOSE
WITHOUT METER	WITH METER			L/MIN	GPM	AC V./HZ DC VOLT	POTENZA WATT	AMP. MAX.	TIPO	TIPO	BSP	LUNGH.
OOO271POO	OOO272POO	DRUM PANTHER 56	D	56	15	230/50	350	3	K33	SELF2000	3/4"	4M
OOO273POO	OOO274POO	DRUM PANTHER 56 A60	D	56	15	230/50	350	3	K33	A60	3/4"	4M
FOO22201A	FOO22205A	DRUM BIPUMP 12V	D	80	21	12V	530	44	K33	SELF2000	1"	4M
FOO22202A	FOO22206A	DRUM BIPUMP 24V	D	80	21	24V	540	22,5	K33	SELF2000	1"	4M
FOO22203A	FOO22207A	DRUM BIPUMP 12V A120	D	80	21	12V	530	44	K33	A120	1"	4M
FOO22204A	FOO22208A	DRUM BIPUMP 24V A120	D	80	21	24V	540	22,5	K33	A120	1"	4M
-	FOO3411IC	DRUM PANTHER DC 24/12V K33 A60	D	56	15	24/12V	150	25/16A	K33	A60	3/4"	4M