

H2101

Valvola a farfalla di tipo wafer /
Butterfly valve wafer type

Valvola a farfalla wafer per
montaggio tra flange / Butterfly
valve installation between flanges



Modello / Model H2101	Materiale / Material EN-GJS-400 - Aisi 316	Tenuta / Seal EPDM - PTFE	DN 50 - 200	PN 10
--	--	-------------------------------------	-----------------------	-----------------

Caratteristiche tecniche / Construction features

- **Montaggio diretto attuatore secondo /**
Direct actuator installation according to
ISO 5211
- **Montaggio tra flange secondo /** Assembly
between flanges according to
EN 1092 PN 10/16 - ANSI 150
- **Scartamento tra le facce /**
Face to face according to
EN 558-1 Serie / series 20
- **Temperatura di esercizio /**
Working temperature
-25°C - + 180°C

Diagramma pressione temperatura / Pressure temperature diagram

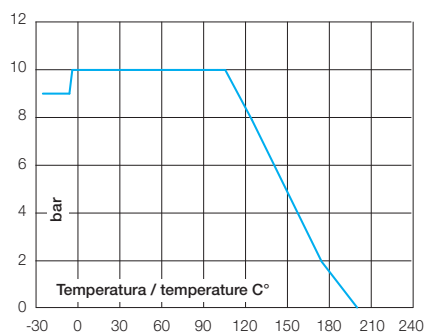

Componenti e materiali / Components and materials

1	Corpo Inferiore / Downside Body	Ghisa nodulare / Ductile Iron EN-GJS-400	11	Rondella / Washer	Acciaio / Steel
	Trattamento superficiale / Surface treatment	Vernice epossidica / Epoxy		Trattamento superficiale / Surface treatment	Trattamento galvanico / Galvanized
2	Corpo Superiore / Upside Body	Ghisa nodulare / Ductile Iron EN-GJS-400	12	Rondella Seeger / Seeger ring	Acciaio / Steel
	Trattamento superficiale / Surface treatment	Vern. epossidica / Epoxy		Trattamento superficiale / Surface treatment	Trattamento galvanico / Galvanized
3	Albero Superiore / Upside Stem	Acciaio inox / SS Aisi 316	13	Maniglia / Handle	Alluminio / Aluminium
4	Albero Inferiore / Downside Stem	Acciaio inox / SS Aisi 316		Trattamento superficiale / Surface treatment	Vern. epossidica / Epoxy
5*	Tenuta / Seal	PTFE + EPDM	14	Piatto / Plate	Acciaio / Steel
6	Disco / Disc	Acciaio inox / SS Aisi 316		Trattamento superficiale / Surface treatment	Trattamento galvanico / Galvanized
	Trattamento superficiale / Surface treatment	Lucidato / Polished	15	Vite-Dado / Screw-Nut	Acciaio / Steel
7	Boccola / Hub	Nylon		Trattamento superficiale / Surface treatment	Trattamento galvanico / Galvanized
8	Rondella molla / Spring washer	Acciaio / Steel	16	Vite / Screw	Acciaio / Steel
	Trattamento superficiale / Surface treatment	Dacromet		Trattamento superficiale / Surface treatment	Trattamento galvanico / Galvanized
9	Anello OR / O-ring	FPM	* Ricambi disponibili / Spare parts		
10	Manicotto / Bush	RPTFE			

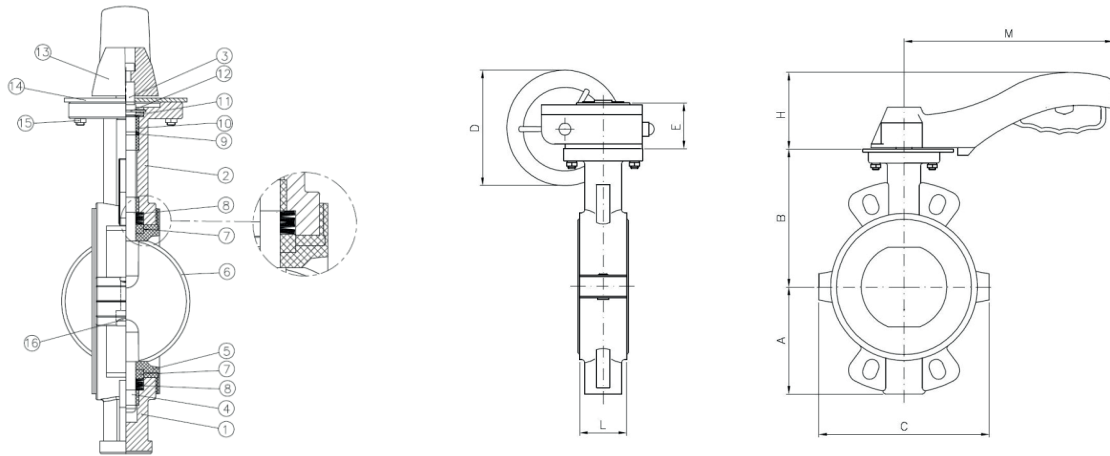

Dimensioni e pesi / Dimensions and weights

Codice Code	Misura Size	DN	PN	Peso in kg. Weight in kg.	KV m ³ /h*	Dimensioni in mm Dimensions in mm									ISO 5211
						L	A	B	C	D	E	H	M		
H210109	2"	50	10	2,90	125	43	80	140	119	-	-	65	172	F05	
H210110	2" 1/2	65	10	3,18	244	46	89	150	131	-	-	65	172	F05	
H210111	3"	80	10	3,55	399	46	95	158	145	-	-	65	172	F05	
H210112	4"	100	10	5,53	727	52	114	176	180	-	-	78	216	F07	
H210113	5"	125	10	6,87	1.190	56	127	190	202	-	-	78	216	F07	
H210114	6"	150	10	8,25	1.600	56	139	210	230	150	72	-	-	F07	
H210116	8"	200	10	17,40	2.868	60	175	236	295	300	85	-	-	F10	

* Disco a 90° / Disc position 90°